

Design of Variable Length Connecting rod for VCR Engine

Savita kumari tomar¹, Reena mishra¹, Sarita bisht¹, Sanjeev kumar¹,
Mr.Gaurav saxena²

¹ B.E scholar, Rustamji Institute of Technology, Gwalior, Madhya Pradesh, India

² Asst. Prof., department of automobile engineering, RJIT, Tekanpur, Madhya Pradesh, India

ABSTRACT:

There is a need for developing high specific power output engine from the point of view of fuel consumption & emission. The maximum power output depends on the utilization of full air capacity of the engine i.e. when maximum amount of fuel burnt effectively. All methods of increasing power output of an engine have their own problems for e.g. increasing engine speed imposes dynamic loads & wear, reduce reliability and life of engine. This also increases pumping losses which are not acceptable especially under part load condition. Variable compression ratio (VCR) technology is a method for improving the fuel economy of SI engines. Spark ignition (SI) engines have lower part-load efficiency when compared with the diesel engines. To achieve high efficiency operate SI engine with high compression ratio at part load and with low compression ratio at high load. So we design a modified connecting rod to increase or decrease the compression ratio at two stages instead of continuously varying the compression ratio. For this connecting rod is modified by designing two hydraulic cylinders in its main body with pistons connected with the eccentric, at small end of connecting rod to achieve desired compression ratio.

Keywords: variable compression ratio engine (VCR), spark ignition (SI), eccentric, one-way check valve, efficiency, Pro-E.

I. Introduction: -

Compression ratio is one of the most important and fundamental parameters, when evaluating the performance of an engine or designing it. The concept of compression ratio, explained here, is one which is a prime factor in deciding the efficiency of any car engine. Compression is squeezing something, so that, it occupies a smaller volume. Ratio is the proportion between two quantities or numerical values. The basic unit of an engine assembly is a combustion chamber and piston combination. This ratio is a proportion which denotes the degree of compression achieved in an internal or external combustion engine, when the driving pistons compress the air-fuel mixture in every engine stroke. It is a ratio of air-fuel mixture volume when a piston is at the end of its up-stroke, to the air-fuel mixture volume at the end of its down stroke in a combustion chamber. The variable compression engine means that the compression ratio of the engine can be controlled at each engine operation condition. When the more power of engine is needed during high load, the compression ratio is decreased, and when the higher efficiency is needed during low load, the compression ratio is increased. Under full load conditions, the performance and efficiency of an engine with a compression ratio that is adapted to load demands

is capable of reducing knock susceptibility. From fig we see how VCR improves engine efficiency & torque.

At low power levels, the VCR engine operates at a higher compression ratio to achieve high fuel efficiency benefits, while at high power levels the engine operates at low compression ratio to prevent knock. The optimum compression ratio is determined as a function of one or more vehicle operating parameters such as inlet air temperature, engine coolant temperature, exhaust gas temperature, engine knock, fuel type, octane rating of fuel, etc. In a VCR engine, the operating temperature is more or less maintained at optimum, where combustion efficiency is high. It has been proven that a VCR engine develops much more power for the same engine dimensions, i.e. it is very compact and has a high power-to-weight ratio without any penalty on specific consumption. Variable compression ratio is becoming increasingly desirable as oil prices increase and car buyers have an increased interest in fuel economy. Variable compression can make Reductions in fuel consumption of up to 30% from fig given below we can see that how varying the compression ratio effect fuel consumption.

1.1 Compression Ratio Definition:-

Compression ratio = $\frac{\text{maximum volume}}{\text{Minimum volume}}$

Compression ratio

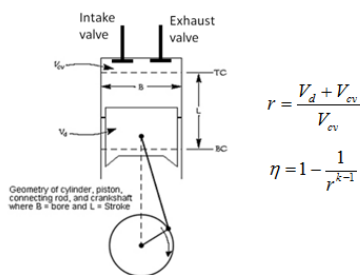

Importance Of Vcr:-

The present challenge in automotive engine technology is the improvement of thermal efficiency and hence the fuel economy and lower emission levels. Compression ratio is the key features which affect thermal efficiency of engine. Higher compression ratio results in higher thermal efficiency and improved fuel economy in the internal combustion engine. Generally, the operating conditions vary widely, such as stop and go city traffic, highway motoring at constant speed, or high-speed freeway driving. In a conventional

SI, the maximum compression ratio is set by the conditions in the cylinder at high load, when the fuel and air consumption are at maximum levels. If the compression ratio is higher than the designed limit, the fuel will pre-ignite causing knocking, which could damage the engine. Unfortunately, most of the time SI engines in city driving conditions operate at relatively low power levels under slow accelerations, low speeds, or light loads, which lead to low thermal efficiency and hence higher fuel consumption. As the engine load decreases, the temperature in the end on thermal efficiency is compression ratio and air-fuel mixture strength. The fuel-air cycle Efficiency gas drops, so that high compression ratio could be employed without the risk of knocking in naturally aspirated or boosted engines. Raising the compression ratio from 8 to 14 produces an efficiency gain from 50 to 65 per cent (15%), whereas going from 16 to 20 produces a gain from 67 to 70 %.

Figure below shows the effects of Compression ratio with respect to thermal efficiency.

Theoretical Efficiency - Air Cycle

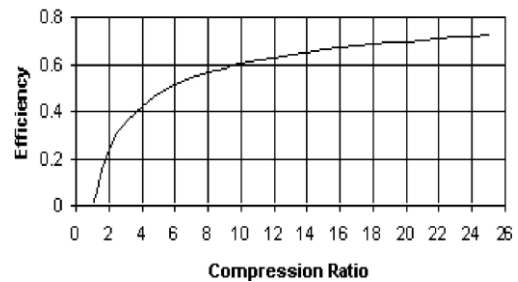

Previous Inventions In Vcr Engine

1.3.1 Moving The Cylinder Head

The moving head concept combines head and liners into a monoblock construction which pivots with respect to the remainder of the engine. SAAB has enabled a tilting motion to adjust the effective height of the piston crown at TDC. The linkage serves to tilt the monohead relative to the crankcase in order to vary the TDC position of the piston. By means of actuator and linkage mechanism the compression ratio can be varied from 8 to 14

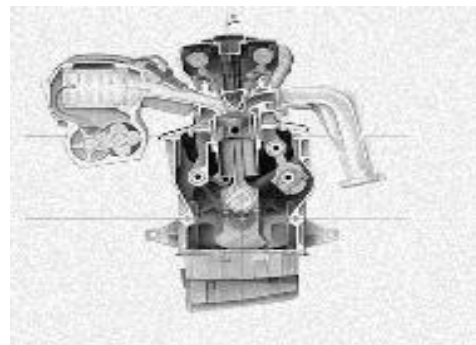

1.3.2 Variation Of Combustion Chamber Volume

In order to vary the combustion chamber volume a secondary piston or valve is used. The piston could be maintained at an intermediate position, corresponding to the optimum compression ratio for a particular condition. The combustion chamber volume is increased to reduce the compression ratio by moving a small secondary piston or valve which communicates with the Chamber.

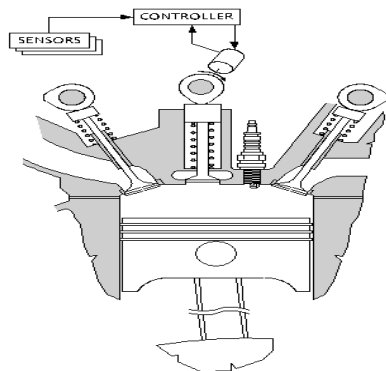

1.3.3 Variation Of Piston Deck Height

The Daimler-Benz VCR piston design shows variation in compression height of the piston and offers potentially the most attractive route to a production VCR engine, since it requires relatively minor changes to the base engine architecture when compared to other options.

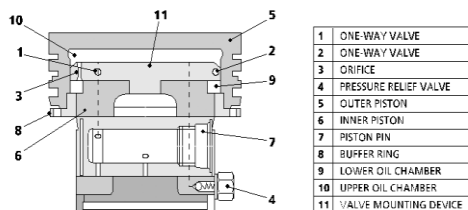

1.3.4 Moving The Crankshaft Axis

In this method a crankshaft bearings are carried in an eccentrically mounted carrier that can rotate to raise or lower the top dead centre (TDC) positions of the pistons in the cylinders. The compression ratio is adjustable by varying the rotation of the eccentric carrier.

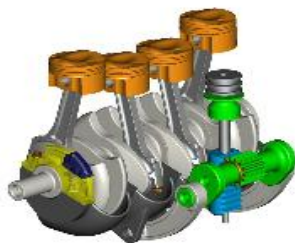

1.3.4 Con Rod Linkages

A popular approach has been developed to replace the conventional con rod with a 2 piece design in which an upper member connects with the piston while a lower member connects with the crankshaft. The shorter crank throw allowed room for the link system, which was anchored by an eccentric rotary actuator.

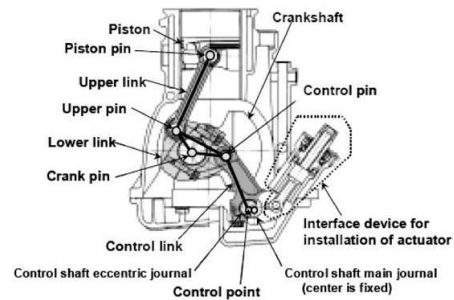

II. Literature Review:-

Amjad Shaik el at [1] reviews the geometric approaches and solutions used to Achieve VCR, consider the results of prior research, and forecasts what benefits, if any, a VCR would bring to present engine design.

Martyn Roberts [2] studied Potential benefits of Variable Compression Ratio (VCR) spark ignition engines are presented, based on an examination of the relationship between Compression Ratio, BMEP and spark advance at light load and full load. Alternative methods of implementing VCR are Illustrated and critically examined.

Tadeusz J. Rychter el at [3] introduced the state-of-art knowledge about the progress in the investigations of the VR/LE concept of the variable compression ratio engine .reviewed Engine kinematics, thermodynamic analysis, research engine design and application of the concept to the turbocharged diesel engine.

GVNSR Ratnakara Rao el at [4] carried out experiments on

a single cylinder four stroke variable compression ratio diesel engine to find out optimum compression ratio. Tests were carried out at compression ratios of 13.2, 13.9, 14.8, 15.7, 16.9, 18.1 and 20.2 results on thermal efficiency due to varying compression ratio are plotted on graph.

Aina T. el at [5] performs experimental and theoretical investigation of the influence of the compression ratio on the brake power, Brake thermal efficiency, brake mean effective pressure and specific fuel consumption of the Ricardo variable compression ratio spark ignition engine. Compression ratios of 5, 6, 7, 8 and 9, and engine speeds of 1100 to 1600rpm, in increments of 100 rpm, were utilized. The results are shown that as the compression ratio increases, the actual fuel consumption decreases averagely by 7.75%, brake thermal efficiency improves by 8.49 % and brake power also improves by 1.34%.

Charles Mendler [6] gives Brief technology overview to vary compression ratio. Initial approaches are given by him .Piggy back the

VCR hydraulic actuator system off of the transmission hydraulic circuit to minimize hardware cost and to minimize additional oil pump power consumption. Implement a new intermittently high-pressure circuit to step-up the transmission oil pressure for powering the VCR & shows Major Finding and New Approach Found after his testing of his VCR engine.

Nitin Wankhade et al [7] comparatively investigate VCR diesel engine for different types of vibration .to analyze the vibration in diesel engine cylinder liner considering combustion gas forces and cylinder liner temperature using finite element software ANSYS. By comparing the analytical results, the validity of the proposed analysis has been tested & evaluated the vibration of different materials along with increase in thickness.

Prof. N.P. Doshi et al [8] performs modeling of connecting rod used in light commercial vehicle of Tata motors had recently been launched in the market using PRO-E wildfire 4.0 software & analysis its design in ANSYS 11 software. They found out the stresses developed in connecting rod under static loading with different loading conditions of compression and tension at crank end and pin end of connecting rod. They have also designed the connecting rod by machine design approach.

Anthony Crawford [9] studied & reviews ways to mitigate knock in VCR engine. Find various benefits of VCR in SI engine shows various VCR systems. . Find various benefits of VCR in SI engine shows various VCR systems.

Hong- Wook Lee et al [10] Developed a concept of Variable Compression Ratio Engine Using TRIZ In this study, TRIZ is applied to develop new concept of VCR engine. Various tools of TRIZ have been used in this study: “Function analysis” is applied to analyze previous VCR models, and “Trimming” to make new contradiction, then “ARIZ” to solve this problem.

III. Analytic Modeling Of Vcr Engine

3.1 Specific Fuel Consumption & Efficiency

The engine torque, T is given by

$$T = WR$$

Where, W is the brake load in Newton and R is the torque arm in meters.

The actual power available at the crank shaft is the brake power, Bp, given by

$$Bp = \frac{\pi NT}{30}$$

Where, N is the engine speed in revolution per minute.

The brake mean effective pressure (BMEP) is the mean effective pressure which would have developed power

Equivalent to the brake power if the engine were frictionless and for a four stroke engine is given by

$$BMEP = \frac{2 Bp}{VsNn}$$

Where, n is the number of cylinders and Vs is the swept volume

The brake thermal efficiency η_{BT} is the ratio of the brake power to the power supplied by the fuel, Q_{in} and is given by

$$\eta_B = \frac{Bp}{Q_{in}}$$

And

$$Q_{in} = mf Q_{LV}$$

Where mf is the mass flow rate of the fuel and Q_{LV} is the lower calorific value of the fuel.

The specific fuel consumption (SFC) is the total fuel consumed per kilowatt power developed and it is given by

$$SFC = \frac{3600 mf}{Bp}$$

3.2 Torque Gain:-

Increase in compression ratio induces greater turning effect on the cylinder crank. That means that the engine is getting more push on the piston, and hence more torque is generated. The torque gain due to compression ratio Increase can be given as the ratio of a new compression ratio (new r c) to the old compression ratio (old r c) given by

$$\text{Torque gain/loss} = (\text{new r c} / \text{old r c})$$

IV. Variable Length Connecting Rod Design

4.1 Principle Of Modified Connecting Rod:-

A variable-length connecting rod, realized by an eccentric piston pin suspension, which utilizes crank train forces to adjust the compression ratio. This system is called the "variable length Conrod "system or "VCRconrod". The moment acting on the eccentric, resulting from superimposed gas and inertia forces, is used to adjust the connecting rod length. The eccentric moment takes on positive as well as negative values during a combustion cycle, making possible an adjustment in both directions.

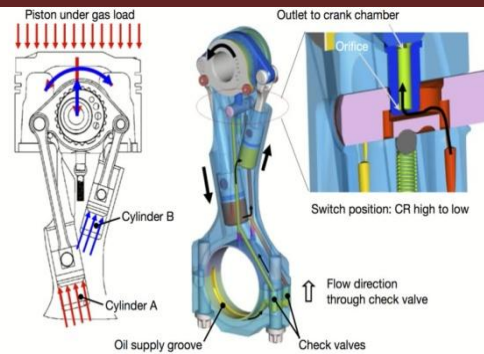
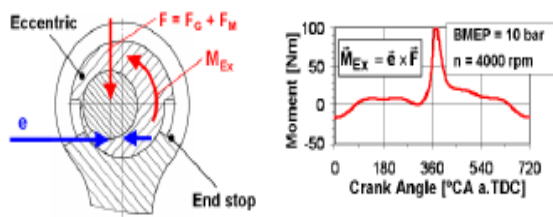

4.2 construction Of Modified Connecting Rod:-

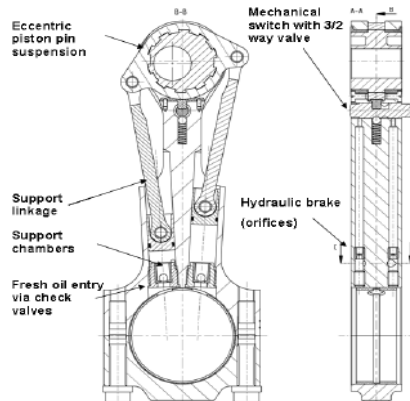

4.4 Pro-E Software Design Of Conrod

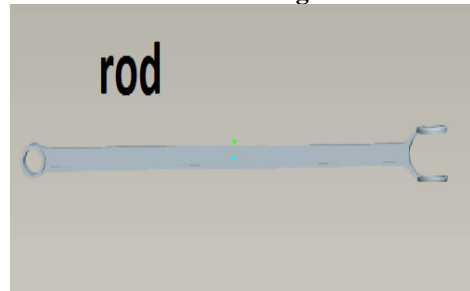

Part model of rod

4.3 Working Of Modified Connecting Rod:-

The two support chambers are connected to the oil circuit via one check valve each, and by means of a 3/2 check valve, a passage from the chamber to the crankcase can be opened. Thus it is possible for one hydraulic piston to enter more deeply into its support chamber, displacing oil from it in the process, while the other support chamber is being filled with oil. Consequently, the eccentric is able to rotate in one direction only. The reversal of the eccentric's direction of rotation can be triggered by actuating the 3/2 way valve, which is designed as a mechanical switch. The reversal is executed by actuating two cam discs in such a way that the valve is axially moved in either the "CR-low" or in the "CR-high" direction (figure 10). The actuation process itself is concluded within one engine revolution. As the valve body is arrested in the respective end position by means of a combination of spring-and-ball catches, any further impacts through subsequent engine revolutions are prevented. The mechanical switch is located just underneath the connecting rod's small eye. The cam discs are located between the envelope of the counterweights of the crankshaft and the piston pin boss. This arrangement has the advantage that the velocity of the valve body is relatively small when getting in contact with the cam discs. On the other hand it requires that the sufficient clearance is available between the counterweight envelope and piston pin boss in BDC position.

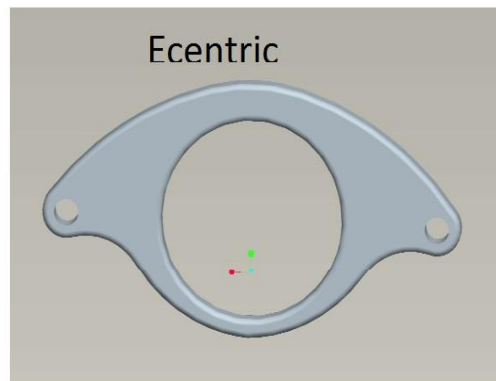

Part model of eccentric

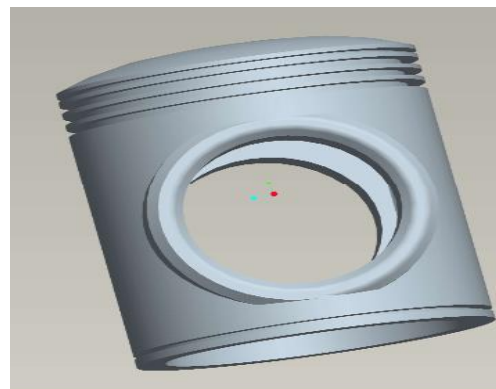

Part model of small piston

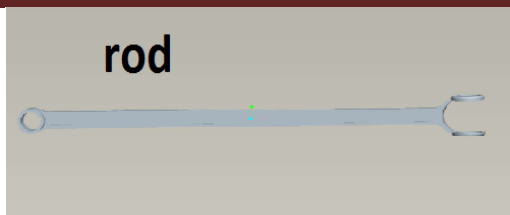

Part model of rod



Part model of big piston

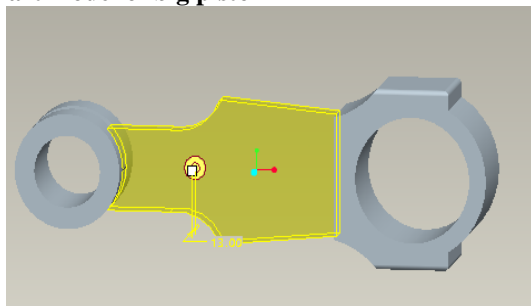

Part model of main connecting rod

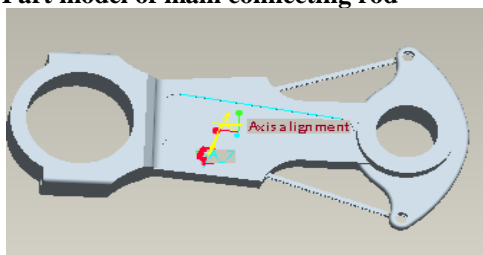

Assembled variable length connecting rod

V. Conclusion & Results:-

VCR systems with certain modification in connecting rod design i.e. hydraulic pistons in connecting rod body & eccentric in connecting rod small end. is the most economical, simplest method to achieve two stage variable compression ratio compared to conventional continuous variable compression ratio system .from this paper we conclude that by this method in VCR system fuel consumption can be reduced about 30% . Greenhouse when they are used in combination with down-sizing gas emissions. VCR, has the ability to down-size the engine, multi-fuel flexibility, and the potential to revise emission characteristics.

Following results are found:-

1. Under full load conditions, the performance and efficiency of an engine with a compression ratio that is adapted to load demands is capable of reducing knock susceptibility.
2. In addition, the risk of pre-ignition, mega-knocking effects and engine jerking, as the result of retarded combustion phases, can be reduced.
3. The VCR also provides further potential to control the exhaust gas temperature, contributing to protecting component temperatures. Combustion, a reduced CR results in a lower peak firing pressure.

References:

- [1] Amajd Shaik, N Shenbaga Vinayaga Moorthi and R. Rudramoorthy "Variable compression ratio engine: a future power plant for automobiles – an overview"2007 (PSG College of Technology).
- [2] Martyn Roberts "Benefits and Challenges of Variable Compression Ratio (VCR)"2002 (Prod -rive Ltd).
- [3] Tadeusz J. Rychter, Andrzejn Teodorczyk "variable compression ratio engine- VR/LE concept"2003(Institute of Heat Engineering Warsaw University of Technology).
- [4] GVNSR Ratnakara Rao , V. Ramachandra Raju, and M. Muralidhara Rao "Optimizing the compression ratio of diesel fuelled CI engine" 2008(College of Engineering JNTU, Hyderabad, India).
- [5] Aina T., Folayan C. O. and Pam G. Y. "Influence of compression ratio on the performance characteristics of a spark ignition engine"2012(Ahmadu -Bello University, Zaria, Nigeria).
- [6] Charles Mendler Envera LLC "Variable Compression Ratio Engine"2009 (California)
- [7] Nitin Wankhade, Prasad Hatwalne Sachin Pente, "Comparative investigation of vibration analysis of VCR diesel engine for different types of grey cast iron"2013 (Department of Mechanical Egg, PRMIT&R, Bandera).
- [8] Prof. N.P. Doshi, Prof .N.K. Ingole " Analysis of Connecting Rod Using Analytical and Finite Element Method" 2013 (Bapurao Deshmukh College of Egg. Sewagram, India).
- [9] Anthony Crawford "Variable Compression Ratio Engine systems" (Ph.D., P.E)
- [10] Hong-Wook Lee, Won Gyu Kim, Myung Rae Cho, "Concept Development of a Variable Compression Ratio Engine Using TRIZ"2010 (Hyundai KIA Motor Company, Korea).